

LP<sup>®</sup> SolidStart<sup>®</sup> Strand Lumber  
Louisiana-Pacific Corporation

PR-L280  
Revised October 30, 2009

Products: LP SolidStart 1.35E, 1.55E, and 1.75E LSL

LP Building Products, Louisiana-Pacific Corporation, 414 Union Street, Suite 2000, Nashville, Tennessee 37219

(615) 986-5600

[www.lpcorp.com](http://www.lpcorp.com)

1. Basis of the product report:

- 2006 International Building Code (IBC): Sections 104.11 Alternative Materials and 2303.1.9 Structural composite lumber
- 2006 International Residential Code (IRC): Section R104.11 Alternative Materials
- ASTM D 5456-03 recognized by the 2006 IBC
- APA Reports T2006P-25, T2006P-26, T2007P-89, T2008P-13, T2008P-39, T2008P-46A, T2008P-49A, T2008P-55, T2008P-66, T2008P-85, T2008P-86, T2008P-94, T2008P-106, T2008P-112, T2009P-04, T2009P-05, T2009P-13, T2009P-25, T2009P-26, T2009P-64, and other qualification data

2. Product description:

LP SolidStart LSL is made with strands of various species and strand classifications in accordance with the in-plant manufacturing standard approved by APA. LP SolidStart LSL is available in a range of thickness (5-1/4 inches maximum), depth and length. Refer to the manufacturer's technical guide ([www.lpcorp.com/findliterature.aspx](http://www.lpcorp.com/findliterature.aspx)) and a local LP Engineered Wood Products distributor for product availability.

LP SolidStart 1.35E and 1.55E LSL can also be used as wall framing in conventional light-frame construction of the applicable code and in engineered wall systems. The minimum thickness of the LSL for wall framing is 1-1/2 inches.

3. Design properties:

Table 1 lists the design properties, Table 2 lists the equivalent specific gravities for fastener design for LP SolidStart LSL, Table 3 lists the allowable loads for rim boards, and Table 4 lists the allowable nail spacing.

3.1 LSL beams, headers, and columns:

The allowable loads for LP SolidStart LSL beams, headers, and columns shall be in accordance with the recommendations provided by the manufacturer (see link above).

3.2 LSL wall framing (1.35E and 1.55E only):

3.2.1 Prescriptive Stud Wall Applications: LP SolidStart LSL used as studs in conventional construction is permitted in accordance with Sections 2308.9.10 and 2308.9.11 of the IBC and Section R602.6 of the IRC.

3.2.2 Engineered Stud Wall Applications: LP SolidStart LSL shall be permitted in engineered wall applications when designed based on net section analysis in accordance with the National Design Specification for Wood Construction (NDS) and the restrictions specified in Section 4.3.2. The allowable design stress for bending and axial compression shall be reduced by a factor of 0.95 and 0.90, respectively, to account for stress concentrations in notches.

The allowable shear values for nailed wood structural panel shear walls using LP® SolidStart® LSL as the wall studs shall be determined using Table 2306.4.1 of the 2006 IBC where the LP SolidStart LSL shall be considered to be equivalent to sawn lumber studs with a specific gravity of 0.50, when subjected to the nailing restrictions specified in Section 4.3.3 of this report.

4. Product installation:

4.1 LSL beams and headers:

LP SolidStart LSL shall be installed in accordance with the recommendations provided by the manufacturer (see link above). Permissible details and allowable hole sizes shall be in accordance with the recommendations provided by the manufacturer.

4.2 LSL columns:

4.2.1 LP SolidStart LSL used as free-standing columns shall not be drilled or notched without the approval of a professional engineer or the manufacturer. Bolts, lag screws, and self-tapping screws shall only be inserted through the face of the column, perpendicular to the face of the strands in LP SolidStart LSL.

4.2.2 LSL built-up columns: When used for built-up columns, LP SolidStart LSL shall be constructed using connections specified by the manufacturer (see link above).

4.3 LSL wall framing (1.35E and 1.55E only):

4.3.1 Prescriptive Stud Wall Applications: Cutting, notching and boring of LP SolidStart LSL used as studs in conventional construction is permitted in accordance with Sections 2308.9.10 and 2308.9.11 of the IBC and Section R602.6 of the IRC. Stud wall nailing restrictions and requirements are presented in Section 4.3.3 of this report.

4.3.2 Engineered Stud Wall Applications: Cutting, notching and boring of LP SolidStart LSL shall be permitted in engineered wall applications with the following restrictions:

- a) One hole up to 40% of the stud depth, maximum of 1-3/8 inches for 2x4 and 2-3/16 inches for 2x6 and wider, is allowed anywhere in the stud height for bearing walls, except that a hole shall not be placed within 6 inches of either end of the stud. Two small holes up to 1 inch diameter and spaced no closer than 12 inches on-center are permitted in studs with a depth of at least 5-1/2 inches. A minimum edge distance of 5/8 inch shall be maintained for all holes.
- b) One notch up to 25% of the stud depth, maximum of 7/8 inch for 2x4 and 1-3/8 inches for 2x6 and wider, is allowed only in the upper or lower 3 feet of the stud height, except that a notch shall not be placed within 6 inches of either end of the stud. The notch length shall not exceed 8 inches.
- c) Holes and notches shall not be cut at the same cross section, and the minimum clear vertical space between hole and notch shall be 2 times the hole diameter or 2 times the notch length, whichever is greater.
- d) Stud wall nailing restrictions and requirements are presented in Section 4.3.3.

4.3.3 Stud Wall Nailing Restrictions and Requirements

- a) For sheathing attached with 10d common nails (0.148 inch x 3 inches) with a spacing no closer than 6 inches on center, a single LP SolidStart LSL stud shall be permitted for framing at adjoining panel edges.
- b) For sheathing attached with 8d common nails (0.131 inch x 2-1/2 inches) or smaller with a spacing no closer than 4 inches on center, a single LP® SolidStart® LSL stud shall be permitted for framing at adjoining panel edges.
- c) For sheathing attached with 8d common nails (0.131 inch x 2-1/2 inches) spaced closer than 4 inches on center or 10d common nails (0.148 inch x 3 inches) spaced

closer than 6 inches on center, a double, stitch-nailed, LSL stud is required at adjoining panel edges. For stud wall applications in accordance with the IRC and the conventional light-frame construction provisions of the IBC (Sections 2308 and Table 2304.9.1), double LSL studs shall be stitch-nailed together with 2 staggered rows of 10d nails (minimum 0.120 inch x 2-7/8 inches) spaced 8 inches in each row. For engineered stud wall applications, the stitch nailing of double LSL studs shall be designed to transfer the required lateral shear using an assumed equivalent specific gravity of 0.50. Panel-edge nails must be installed a minimum 3/8 inch from the panel edges and must be staggered a minimum of 1/4 inch within each line of nails.

- d) Nails shall not be spaced closer than 3 inches on center.
- e) Maximum nail size is 10d common (0.148 inch x 3 inches).

5. Fire-rated assemblies:

- 5.1 The provisions of IBC Section 721.6.3, design of fire-resistant exposed wood members, shall be applicable to LP SolidStart LSL when used as a bending member (beam and header). Fire-rated assemblies shall be constructed in accordance with the recommendations provided by APA Design/Construction Guide: Fire-Rated Systems, Form W305 ([www.apawood.org/publications](http://www.apawood.org/publications)), and the manufacturer.
- 5.2 When used as wall studs, LP SolidStart 1.35E and 1.55E LSL is permitted to be used in fire-resistance-rated construction and may be considered a direct replacement for solid-sawn lumber of No. 2 or lower grades, having the same dimensions, in any fire-resistance-rated wall assemblies listed in Table 720.1(2) of the IBC. A minimum of 2.5 lbf/ft<sup>3</sup> mineral wool insulation shall be placed in the stud cavity.
- 5.3 As an alternative to the prescriptive fire-resistance-rated wall assemblies listed in Table 720.1(2) of the IBC, a one-hour fire-resistance-rated wall assembly shall be permitted to be designed and constructed with the limitations listed below, provided that the applied axial stress on each stud does not exceed 440 psi for 1.55E and 380 psi for 1.35E LP SolidStart LSL. When the slenderness ratio exceeds 33, the  $F_c'$ , which is the  $F_{cl}$  value tabulated in Table 1 for each stud grade adjusted for all applicable adjustment factors, including column stability factor, in accordance with NDS, shall be multiplied by 0.77.
  - a) The stud spacing shall be no greater than 24 inches on center,
  - b) The top and bottom plates of the wall shall be constructed in accordance with the nailing schedule specified in Table 2304.9.1 of the 2006 IBC or Table R602.3(1) of the 2006 IRC.
  - c) The wall shall be covered with one layer of 5/8-inch Type X gypsum wall board attached to studs with 2-1/4-inch long Type S drywall screws at 7 inches on center on the perimeter and in the field, and
  - d) A minimum of 2.5 lbf/ft<sup>3</sup> mineral wool insulation shall be placed in the stud cavity.

6. Limitations:

- a) LP SolidStart LSL shall be designed in accordance with the code using the design properties and installation requirements specified in this report.
- b) LP SolidStart LSL is limited to dry service conditions where the equivalent moisture content of sawn lumber is less than 16 percent.
- c) LP SolidStart LSL is produced by Louisiana-Pacific Corporation facility in Houlton, Maine under a quality assurance program audited by APA.
- d) This report is subject to re-examination in one year.

7. Identification:

The LP® SolidStart® LSL described in this report are identified by a label bearing the manufacturer's name (Louisiana-Pacific Corporation) and/or trademark, the APA assigned plant number (1092), the product grade, the APA-EWS logo, the report number PR-L280, and a means of identifying the date of manufacture.

Table 1. Design Properties (Allowable Stress Design) for LP SolidStart LSL<sup>(a,b)</sup>

Property		Design Stress (psi)		
		1.35E	1.55E	1.75E
Bending (F <sub>b</sub> ) <sup>(c)</sup>	Joist <sup>(d)</sup>	1,730	2,360	2,500
	Plank	1,910	2,620	2,800
Tension parallel to grain (F <sub>t</sub> ) <sup>(e)</sup>		1,300	1,750	2,100
Longitudinal shear (F <sub>v</sub> )	Joist	410	410	410
	Plank	155	155	155
Compression parallel (F <sub>c  </sub> )		1,650	2,175	2,450
Compression perpendicular (F <sub>c⊥</sub> )	Joist	750	875	950
	Plank	440	440	440
Modulus of Elasticity <sup>(f)</sup> , (E)		1.35 x 10 <sup>6</sup>	1.55 x 10 <sup>6</sup>	1.75 x 10 <sup>6</sup>

For SI: 1 inch = 25.4 mm, 1 foot = 304.8 mm, 1 lbf = 4.448 N, 1 psi = 6.9 kPa.

- (a) The tabulated values are design values for normal duration of load. All values, except for E and F<sub>c⊥</sub>, are permitted to be adjusted for other load durations as permitted by the code. The design stresses are limited to conditions in which the equivalent moisture content of sawn lumber does not exceed 16 percent.
- (b) Allowable stresses for "Joist" refer to loads applied parallel to the wide face of the strands (the edge of the member). "Plank" refers to loads applied perpendicular to the wide face of the strands (the face of the member).
- (c) Tabulated flexural stress (F<sub>b</sub>) may be increased by 4 percent when the member qualifies as a repetitive member as defined in the NDS.
- (d) The tabulated values are based on a reference depth of 12 inches. For other depths, when loaded edgewise, the allowable bending stress (F<sub>b</sub>) shall be modified by  $(\frac{12}{d})^{0.143}$ , as shown in the following table for common depths. For depths less than 3-1/2 inches, the factor for the 3-1/2-inch depth shall be used.

Depth (in.)	3-1/2	5-1/2	7-1/4	9-1/4	9-1/2	11-1/4	11-7/8	16	18
Multiply by	1.19	1.12	1.07	1.04	1.03	1.01	1.00	0.96	0.94

- (e) The tabulated values are based on a reference length of 3 feet. For other lengths, the allowable tensile stress shall be modified by  $(\frac{3}{\ell})^{0.092}$ , where  $\ell$  = length in feet. For lengths less than 3 feet, use the allowable tension stresses in Table 1 unadjusted.
- (f) The tabulated modulus of elasticity is the shear-free MOE. For uniformly loaded simple-span beams deflection is calculated as follows:

$$\delta = \frac{270 wL^4}{Ebh^3} + \frac{28.8 wL^2}{Ebh}$$

Where:  $\delta$  = estimated deflection, inches,      w = uniform load, plf  
 L = span, feet,      E = tabulated modulus of elasticity, psi  
 b = beam width, inches, and      h = beam depth, inches

Table 2. Fastener Design for LP® SolidStart® LSL<sup>(a,b,c)</sup>

Equivalent Specific Gravity (S.G.)					
Nails and Wood Screws				Bolts and Lag Screws <sup>(d,e)</sup>	
Withdrawal Load		Lateral Load		Lateral Load	
Installed in Edge	Installed in Face	Installed in Edge	Installed in Face	Installed in Face	
				Parallel to Grain	Perpendicular to Grain
0.46	0.50	0.50	0.55	0.50	0.58

- <sup>(a)</sup> Fastener types and orientation not specifically described above are beyond the scope of this report.  
<sup>(b)</sup> Fastener design values calculated using the tabulated equivalent specific gravities given above must be adjusted by the applicable adjustment factors specified in the NDS for connection.  
<sup>(c)</sup> Fastener spacing, and end and edge distances must be as specified in the NDS, except that nail spacing and end distance must be as specified in Table 4.  
<sup>(d)</sup> Bolts and lag screws shall only be installed into the face (plank orientation) of the LSL.  
<sup>(e)</sup> The capacities for 1/2" (12.7 mm) diameter lag screws installed into LP SolidStart LSL Rim Board for ledge attachment shall be in accordance with Table 3.

Table 3. Allowable Loads for LP SolidStart LSL Rim Boards<sup>(a)</sup>

Grade	Thickness (in.)	Lateral Load <sup>(b,c)</sup> (lbf/ft)	Vertical Uniform Load <sup>(d)</sup> (lbf/ft)		Vertical Concentrated Load (lbf)	Lateral Resistance for 1/2- inch-dia. Lag Screws (lbf)
			Depth ≤ 16"	16" < Depth ≤ 24"	Depth ≤ 24"	
1.35E and above	1-1/4	250	6,000	3,800	3,800	450
	≥ 1-1/2	280	7,000	4,500	4,500	475

For SI: 1 inch = 25.4 mm, 1 foot = 304.8 mm, 1 lbf = 4.448 N, 1 lbf/ft = 14.6 N/m.

- <sup>(a)</sup> The tabulated lateral load capacity is based on the short-term load duration (10 minutes). The vertical uniform and vertical concentrated load are not permitted to be adjusted for any load durations.  
<sup>(b)</sup> Toe-nailed connections are not limited by the 150 lbf/ft lateral load capacity noted for Seismic Design Categories D, E and F in Section 2305.1.4 of the IBC.  
<sup>(c)</sup> The nailing schedule for sheathing to rim and rim board to sill plate (toe-nailed) is based on 8d box (0.113" x 2-1/2") nails at 6 inches on center (refer to APA W345, *APA Performance Rated Rim Boards*® for full details). Commercial framing connectors may be used to achieve lateral load capacities exceeding the values shown in this table. Calculations shall be based on the equivalent specific gravity values listed in Table 2 subjected to the nailing spacing provided in Table 4.  
<sup>(d)</sup> The allowable vertical uniform load capacity is based on the strength of the rim board and may need to be reduced based on the bearing capacity of the supporting wall plate.

Table 4. Minimum Allowable Nail Spacings for LP® SolidStart® LSL<sup>(a)</sup>

LSL Grade	Thickness (in.)	Orientation	Nail Size <sup>(b,c)</sup> (Common or Box)	Minimum End Distance (in.)	Minimum Nail Spacing (in.)	
					Single Row	Multiple Rows <sup>(d,e)</sup>
1.35E	1 ≤ Thickness < 1-1/2	Edge <sup>(f)</sup>	12d or smaller	2	4	NR <sup>(k)</sup>
			16d	NR <sup>(h)</sup>	NR <sup>(i)</sup>	
		Face <sup>(g)</sup>	12d or smaller	7/8	1	1
			16d	7/8	1-1/2	1-1/2
1.35E, 1.55E, 1.75E	Thickness ≥ 1-1/2	Edge <sup>(f)</sup>	8d & smaller	2	3	3
			10d & 12d	2	3	4
			16d	2-1/2	4 <sup>(j)</sup>	6
		Face <sup>(g)</sup>	12d or smaller	7/8	1	1
			16d	7/8	1-1/2	1-1/2

For SI: 1 inch = 25.4 mm.

- (a) Edge distance shall be sufficient to prevent splitting.
- (b) 16d sinkers (0.148" x 3-1/4") may be spaced the same as a 12d common wire nail (0.148" x 3-1/4").
- (c) Fastener sizes and closest on-center spacing not specifically described above are beyond the scope of this report.
- (d) Multiple rows must be spaced 1/2 inch or more from each other and offset one-half of the tabulated minimum nail spacing, as shown in Figure 1.
- (e) Multiple rows must be equally spaced from the centerline of the narrow face axis.
- (f) Nail penetration for edge nailing shall not exceed 2 inches for 16d nails (common or box) and 2-1/2 inches for 10d and 12d nails (common or box).
- (g) Tabulated closest on-center spacing for face orientation is applicable to nails that are installed in rows parallel to the grain (length) of the LSL. For nails installed in rows perpendicular to the direction of grain (width/depth) of the LSL, the closest on-center spacing for face orientation shall be sufficient to prevent splitting of the LSL.
- (h) Not recommended except that the minimum end distance is permitted to be: (a) 2 inches when the LSL is 1-1/4 inches or thicker and nail penetration is limited to 1-3/8 inches, or (b) 2-1/2 inches when the LSL is 1-1/8 inches or thicker.
- (i) Not recommended except that the minimum nail spacing is permitted to be: (a) 4 inches when the LSL is 1-1/4 inches or thicker and nail penetration is limited to 1-3/8 inches, or (b) 5 inches when the LSL is 1-1/8 inches or thicker.
- (j) Minimum nail spacing may be reduced to 3 inches when the LSL is 1-3/4 inches or thicker.
- (k) Not recommended.

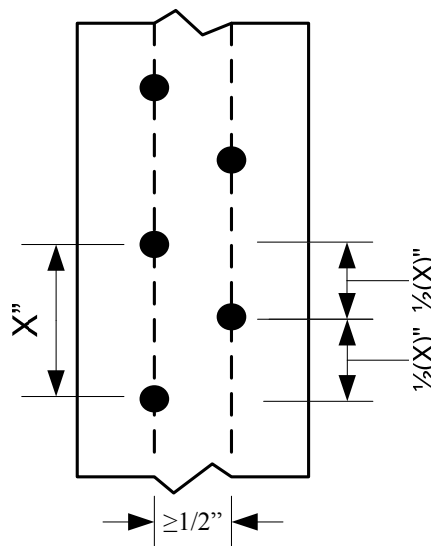

Figure 1. Spacing of multiple rows of nails.

*APA – The Engineered Wood Association* is an accredited certification body under ISO 65 by Standards Council of Canada (SCC) and an accredited inspection agency by the International Code Council (ICC) International Accreditation Service (IAS) under ISO/IEC 17020. APA is also an accredited testing organization recognized by IAS and SCC under ISO/IEC 17025. APA is a recognized testing laboratory by Miami-Dade County, and a Product Testing Laboratory, Product Quality Assurance Entity, and Product Validation Entity by the Florida Department of Community Affairs (DCA).

**APA – THE ENGINEERED WOOD ASSOCIATION  
HEADQUARTERS**

7011 So. 19<sup>th</sup> St. • Tacoma, Washington 98466  
Phone: (253) 565-6600 • Fax: (253) 565-7265 • Internet Address: [www.apawood.org](http://www.apawood.org)

**PRODUCT SUPPORT HELP DESK**  
(253) 620-7400 • E-mail Address: [help@apawood.org](mailto:help@apawood.org)

**DISCLAIMER**

APA Product Report® is a trademark of *APA – The Engineered Wood Association*, Tacoma, Washington. The information contained herein is based on the product evaluation in accordance with the references noted in this report. Neither APA, nor its members make any warranty, expressed or implied, or assume any legal liability or responsibility for the use, application of, and/or reference to opinions, findings, conclusions, or recommendations included in this report. Consult your local jurisdiction or design professional to assure compliance with code, construction, and performance requirements. Because APA has no control over quality of workmanship or the conditions under which engineered wood products are used, it cannot accept responsibility of product performance or designs as actually constructed.